

# STALKBUSTER GEARBOX CAP

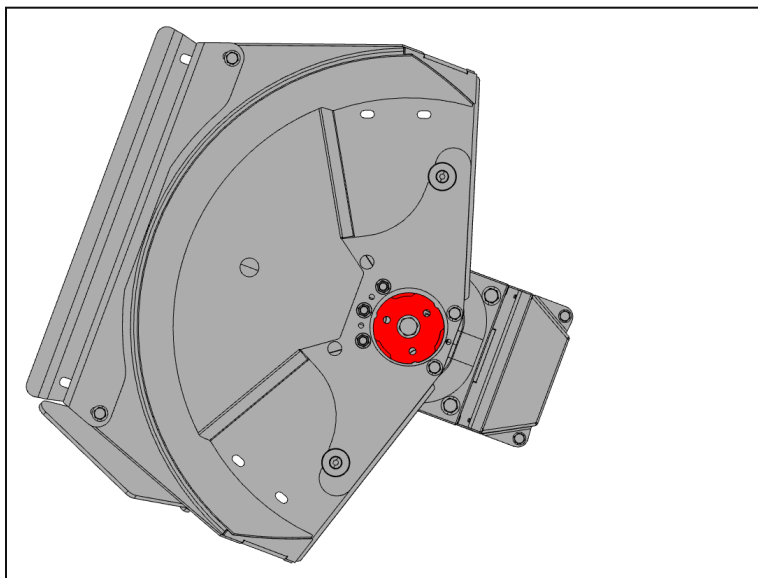

While harvesting without StalkBuster™ function, the gear case flange has to be protected by the cap.



### Installation time:

approx. 20 min.



### Package contents:

- Gearbox cap



For the correct usage  
please check the operat-  
ing manual

Header type	Part number	Quantity
460plus StalkBuster™	LCA123229	8